

Do you need a Party Wall Surveyor?

It is not unusual to receive a notice from your neighbour announcing works to the Party Wall or Adjacent Excavations. Similarly, how do you inform your neighbour of works you plan to carry out?

How do I respond as the neighbour?

The Party wall etc Act 1996 came into force in 1997 to provide a framework for resolving disputes between neighbours in respect of Party Walls, Party Fence Walls and Adjacent Excavations. The Act also deals

Although the Act is fairly complex, the procedure to resolve a dispute between your neighbour is fairly straight forward. On receipt of a notice from your neighbour, which is normally served by a surveyor acting for your neighbour (Building Owner), you have the opportunity to either consent or dissent. If you dissent on the basis that you require your interest to be considered and protected then you should appoint a surveyor. Please note that your appointed surveyor is administering the Act impartially and not representing you as a client. **“It is also important to note that in almost every situation your surveyor’s fees will be paid for by your neighbour instigating the work, except in very rare instances”.** The two surveyors then



How do I inform my neighbour of my proposed works?

If you are carrying out works then you must inform your neighbour (Adjoining Owner) of your intentions in the same way. The best way to start the process is to engage the services of a qualified surveyor to prepare and serve the necessary notices in advance of the works commencing.

Notices for works to a Party Wall must be served two months before they commence or one month if you are excavating foundations within a certain distance of your neighbour’s building or structure.

For information on whether your works will affect your neighbour or you feel that you are at risk from a proposed development then please refer to the diagrams on the reverse side of this page to find the definitions of a Party Wall, Party Fence Wall, Party Structure and prescribed distances for Adjacent Excavation works. These diagrams are to be used as a guide. Further information can be found at our website www.mnasurveyors.co.uk or alternatively on the government website www.communities.gov.uk/partywall-1996.

We are committed to assist Building Owners and Adjoining Owners in resolving disputes and managing the requirements of the Act, so if we can be of any assistance then please contact us.

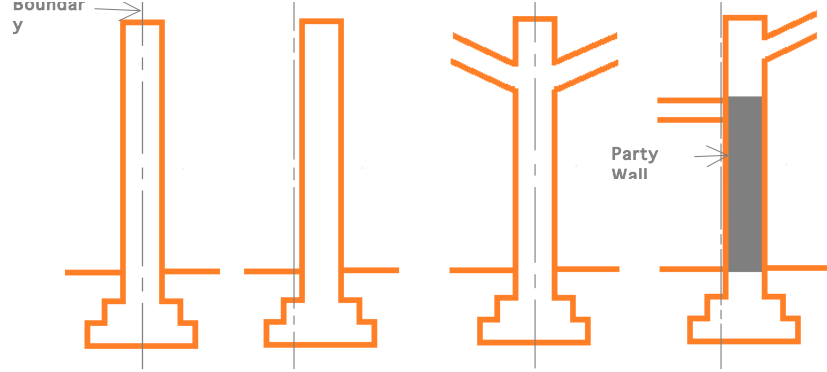

Party Fence Wall Not a Party Fence wall Party Wall def (a)

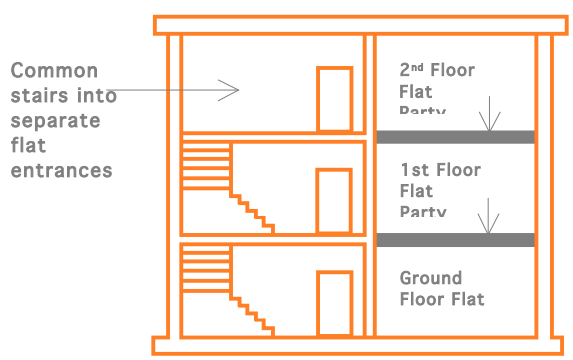

Party Structure - Floor/ceiling between

What work can you do to a Party Wall/Party Fence Wall/Party Structure under the Act?

Underpinning, thicken, raise, demolish and rebuild, remove projections, insert a chemical damp proof course, remove projections, insert beams and structure, reduce in height, convert a Party Fence Wall into a Party Wall, permanently expose a Party Wall, carry out repairs.

What work can't you do to a Party Wall/Party Fence Wall/Party Structure under the Act?

Create openings for doors and windows, flues, air vents, overflows and permanently remove a Party Wall/Party Fence Wall/Party Structure.

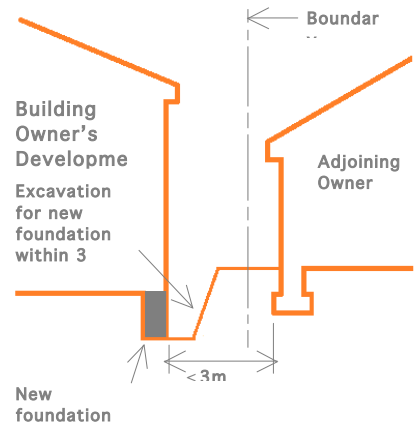

3 metre notice diagram

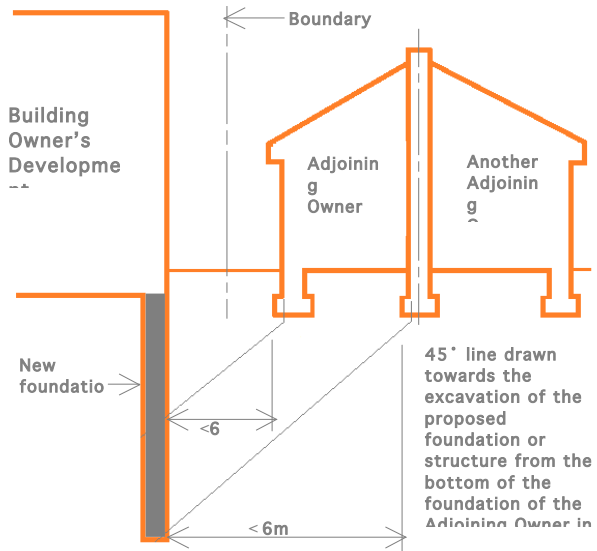

6 metre notice